

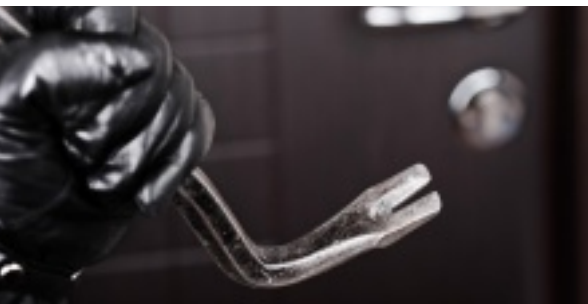

BURGLARY RESISTANT  
**DRUG CABINET** FOR  
HOSPITALS, DOCTOR'S  
SURGERIES AND  
PHARMACIES



# DRUG CABINET

STORAGE FOR PRESCRIPTION DRUGS



## KEY FEATURES

- Suitable for storage of prescription drugs
- Ideal for hospitals, doctor's surgeries, pharmacies or any other situation where securing stock is required
- Supplied with key lock
- Constructed from 10mm solid steel
- Each model is supplied with shelves
- Available in 3 sizes
- Welded strap on lock body
- Boltwork encased when retracted
- Complies with all state codes.

# DRUG CABINET

## PRODUCT SPECIFICATIONS

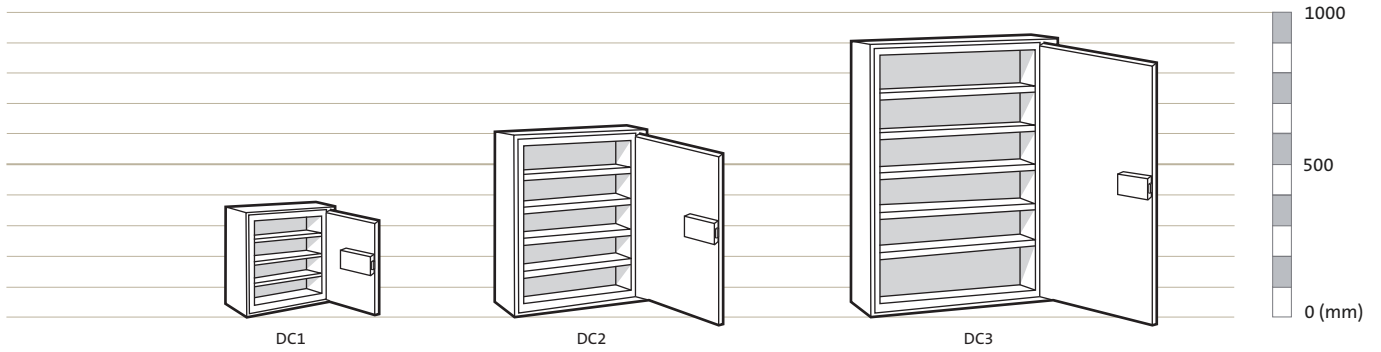

Model	Ext. Height (mm)	Ext. Width (mm)	External Depth (mm)	Int. Height (mm)	Int. Width (mm)	Int. Depth (mm)	Volume (litres)	Weight (kg)
DC1	350	240	150	330	220	130	10	27
DC2	600	450	150	580	430	130	32	66
DC3	900	600	300	880	580	260	132	160

\* In electronic models, add 20mm to allow for keypad projection.

## CONSTRUCTION

### DOOR & BODY

The Drug Cabinet is made from 10mm thick steel.

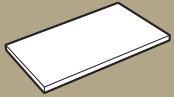

### INTERIOR FITTINGS

#### SHELF

The DC1 Model comes with 3 internal shelves  
 The DC2 Model comes with 4 internal shelves  
 The DC3 Model comes with 5 internal shelves

## LOCKS

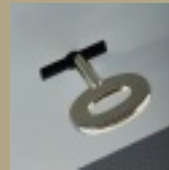

### KEY LOCK

The Drug Cabinet is supplied with a key lock opened by turning the key. The double-bitted key lock used is supplied with two identical keys.

[www.chubbsafes.com.au](http://www.chubbsafes.com.au)